

DATA SHEET

AX521

Analog Input/Output Module



1 Ordering Data

Part no.	Description	Product life cycle phase *)
1SAP 250 100 R0001	AX521, analog input/output module, 4 AI, 4 AO, U/I/Pt100, 12 bits + sign, 2-wires	Active
1SAP 450 100 R0001	AX521-XC, analog input/output module, 4 AI, 4 AO, U/I/Pt100, 12 bits + sign, 2-wires, XC version	Active



*) Modules in lifecycle Classic are available from stock but not recommended for planning and commissioning of new installations.

2 Dimensions

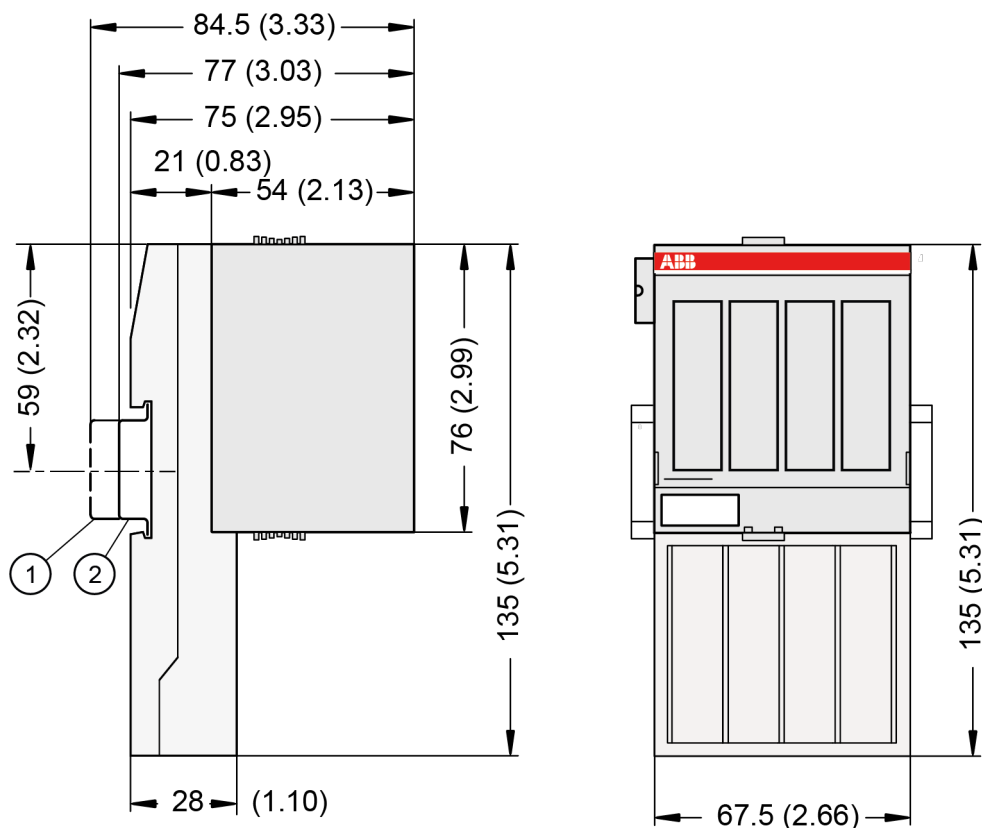

- 1 Din rail 15 mm
- 2 Din rail 7.5 mm



The dimensions are in mm and in brackets in inch.

3 Technical data

The system data of AC500 and S500 ↗ Chapter 4 “System data AC500” on page 5 are applicable to the standard version.

The system data of AC500-XC ↗ Chapter 5 “System data AC500-XC” on page 10 are applicable to the XC version.

Only additional details are therefore documented below.

The technical data are also applicable to the XC version.

Parameter	Value
Process voltage	
Connections	Terminals 1.8, 2.8, 3.8 and 4.8 for +24 V (UP) as well as 1.9, 2.9, 3.9 and 4.9 for 0 V (ZP)
Rated value	24 V DC
Max. ripple	5 %

Parameter		Value
	Protection against reversed voltage	Yes
	Rated protection fuse on UP	10 A fast
	Galvanic isolation	Yes, per module
Current consumption		
	From 24 V DC power supply at the terminals UP/L+ and ZP/M of the CPU/communication interface module	Ca. 2 mA
	From UP at normal operation	0.15 A + output loads
Inrush current from UP (at power up)		0.020 A ² s
Max. length of analog cables, conductor cross section > 0.14 mm ²		100 m
Weight		300 g
Mounting position		Horizontal or vertical with derating (output load reduced to 50 % at 40 °C per group)
Cooling		The natural convection cooling must not be hindered by cable ducts or other parts in the switchgear cabinet.

NOTICE!
Attention:

All I/O channels (digital and analog) are protected against reverse polarity, reverse supply, short circuit and continuous overvoltage up to 30 V DC.

3.1 Technical data of the analog inputs

Parameter	Value
Number of channels per module	4
Distribution of channels into groups	1 group of 4 channels
Connections of the channels I0- to I3-	Terminals 1.0 to 1.3
Connections of the channels I0+ to I3+	Terminals 2.0 to 2.3
Input type	Bipolar (not with current or Pt100/Pt1000/Ni1000)
Galvanic isolation	Against internal supply and other modules
Configurability	0 V...10 V, -10 V...+10 V, 0 mA...20 mA, 4 mA...20 mA, Pt100/1000, Ni1000 (each input can be configured individually)
Channel input resistance	Voltage: > 100 kΩ Current: ca. 330 Ω
Time constant of the input filter	Voltage: 100 μs Current: 100 μs
Indication of the input signals	One LED per channel
Conversion cycle	2 ms (for 8 inputs + 8 outputs), with Pt/Ni... 1 s

Parameter	Value
Resolution	Range 0 V...10 V: 12 bits Range -10 V...+10 V: 12 bits + sign Range 0 mA...20 mA: 12 bits Range 4 mA...20 mA: 12 bits
Conversion error of the analog values caused by non-linearity, adjustment error at factory and resolution within the normal range	Typ. ±0.5 % of full scale at 25 °C
	Max. ±1 % of full scale (all ranges) at 0 °C...60 °C or EMC disturbance
Relationship between input signal and hex code	See tables
Unused voltage inputs	Are configured as "unused"
Unused current inputs	Have a low resistance, can be left open-circuited
Overvoltage protection	Yes

3.2 Technical data of the analog inputs, if used as digital inputs

Parameter	Value
Number of channels per module	Max. 4
Distribution of channels into groups	1 group of 4 channels
Connections of the channels I0+ to I3+	Terminals 2.0 to 2.3
Reference potential for the inputs	Terminals 1.9, 2.9, 3.9 and 4.9 (ZP)
Input signal delay	Typ. 8 ms, configurable from 0.1 to 32 ms
Indication of the input signals	1 LED per channel
Input signal voltage	24 V DC
Signal 0	-30 V...+5 V
Undefined signal	+5 V...+13 V
Signal 1	+13 V...+30 V
Input current per channel	
Input voltage +24 V	Typ. 7 mA
Input voltage +5 V	Typ. 1.4 mA
Input voltage +15 V	Typ. 4.3 mA
Input voltage +30 V	< 9 mA
Input resistance	ca. 3.5 kΩ

3.3 Technical data of the analog outputs

Parameter	Value
Number of channels per module	4, all channels for voltage and current
Distribution of channels into groups	1 group of 4 channels
Channels O0-...O3-	Terminals 3.0...3.3

Parameter	Value
Channels O0+...O3+	Terminals 4.0...4.3
Output type	Bipolar with voltage, unipolar with current
Galvanic isolation	Against internal supply and other modules
Configurability	-10 V...+10 V, 0 mA...20 mA, 4 mA...20 mA (each output can be configured individually), current outputs only channels 0...3
Output resistance (load), as current output	0 Ω...500 Ω
Output loadability, as voltage output	Max. ±10 mA
Indication of the output signals	One LED per channel
Resolution	12 bits (+ sign)
Settling time for full range change (resistive load, output signal within specified tolerance)	Typ. 5 ms
Conversion error of the analog values caused by non-linearity, adjustment error at factory and resolution within the normal range	Typ. ±0.5 % of full scale at 25 °C
	Max. ±1 % of full scale (all ranges) at 0 °C...60 °C or EMC disturbance
Relationship between output signal and hex code	See table
Unused outputs	Can be left open-circuited

4 System data AC500

4.1 Environmental conditions

Table 1: Process and supply voltages

Parameter	Value
24 V DC	
Voltage	24 V (-15 %, +20 %)
Protection against reverse polarity	Yes
120 V AC	
Voltage	120 V (-15 %, +10 %)
Frequency	50/60 Hz (-6 %, +4 %)
230 V AC	
Voltage	230 V AC (-15 %, +10 %)
Frequency	50/60 Hz (-6 %, +4 %)
120 V AC...240 V AC wide-range supply	
Voltage	120 V...240 V (-15 %, +10 %)
Frequency	50/60 Hz (-6 %, +4 %)
Allowed interruptions of power supply, according to EN 61131-2	

Parameter	Value
DC supply	Interruption < 10 ms, time between 2 interruptions > 1 s, PS2
AC supply	Interruption < 0.5 periods, time between 2 interruptions > 1 s

**NOTICE!**

Exceeding the maximum power supply voltage for process or supply voltages could lead to unrecoverable damage of the system. The system might be destroyed.

**NOTICE!**

Improper voltage level or frequency range which cause damage of AC inputs:

- AC voltage above 264 V
- Frequency below 47 Hz or above 62.4 Hz

**NOTICE!**

Improper connection leads cause overtemperature on terminals.

PLC modules may be destroyed by using wrong cable type, wire size and cable temperature classification.

Parameter	Value
Temperature	
Operating	0 °C...+60 °C: Horizontal mounting of modules. 0 °C...+40 °C: Vertical mounting of modules. Output load reduced to 50 % per group.
Storage	-40 °C...+70 °C
Transport	-40 °C...+70 °C
Humidity	Max. 95 %, without condensation
Air pressure	
Operating	> 800 hPa / < 2000 m
Storage	> 660 hPa / < 3500 m
Ingress protection	IP20

4.2 Creepage distances and clearances

The creepage distances and clearances meet the requirements of the overvoltage category II, pollution degree 2.

4.3 Insulation test voltages, routine test

According to EN 61131-2

Parameter	Value	
230 V circuits against other circuitry	2500 V	1.2/50 μ s
120 V circuits against other circuitry	1500 V	1.2/50 μ s
120 V...240 V circuits against other circuitry	2500 V	1.2/50 μ s
24 V circuits (supply, 24 V inputs/outputs, analog inputs/outputs), if they are galvanically isolated against other circuitry	500 V	1.2/50 μ s
COM interfaces, galvanically isolated	500 V	1.2/50 μ s
COM interfaces, electrically not isolated	Not applicable	Not applicable
FBP interface	500 V	1.2/50 μ s
Ethernet	500 V	1.2/50 μ s
ARCNET	500 V	1.2/50 μ s
230 V circuits against other circuitry	1350 V	AC 2 s
120 V circuits against other circuitry	820 V	AC 2 s
120 V...240 V circuits against other circuitry	1350 V	AC 2 s
24 V circuits (supply, 24 V inputs/outputs, analog inputs/outputs), if they are galvanically isolated against other circuitry	350 V	AC 2 s
COM interfaces, galvanically isolated	350 V	AC 2 s
COM interfaces, electrically not isolated	Not applicable	Not applicable
FBP interface	350 V	AC 2 s
Ethernet	350 V	AC 2 s
ARCNET	350 V	AC 2 s

4.4 Power supply units

For the supply of the modules, power supply units according to SELV or PELV specifications must be used.



Safety Extra Low Voltage (SELV) and Protective Extra Low Voltage (PELV)

To ensure electrical safety of AC500/AC500-eCo extra low voltage circuits, 24 V DC supply, communication interfaces, I/O circuits, and all connected devices must be powered from sources meeting requirements of SELV, PELV, class 2, limited voltage or limited power according to applicable standards.



WARNING!

Improper installation can lead to death by touching hazardous voltages!

To avoid personal injury, safe separation, double or reinforced insulation and separation of the primary and secondary circuit must be observed and implemented during installation.

- Only use power converters for safety extra-low voltages (SELV) with safe galvanic separation of the primary and secondary circuit.
- Safe separation means that the primary circuit of mains transformers must be separated from the secondary circuit by double or reinforced insulation. The protective extra-low voltage (PELV) offers protection against electric shock.

4.5 Electromagnetic compatibility

Table 2: Range of use

Parameter	Value
Industrial applications	Yes
Domestic applications	No

Table 3: Immunity against electrostatic discharge (ESD), according to IEC 61000-4-2, zone B, criterion B

Parameter	Value
Electrostatic voltage in case of air discharge	8 kV
Electrostatic voltage in case of contact discharge	4 kV, in a closed switchgear cabinet 6 kV ¹⁾
ESD with communication connectors	In order to prevent operating malfunctions, it is recommended, that the operating personnel discharge themselves prior to touching communication connectors or perform other suitable measures to reduce effects of electrostatic discharges.
ESD with connectors of terminal bases	The connectors between the Terminal Bases and processor modules or Communication Modules must not be touched during operation. The same is valid for the I/O bus with all modules involved.

¹⁾ High requirement for shipping classes are achieved with additional specific measures (see specific documentation).

Table 4: Immunity against the influence of radiated (CW radiated), according to IEC 61000-4-3, zone B, criterion A

Parameter	Value
Test field strength	10 V/m

Table 5: Immunity against fast transient interference voltages (burst), according to IEC 61000-4-4, zone B, criterion B

Parameter	Value
Supply voltage units (DC)	2 kV
Supply voltage units (AC)	2 kV
Digital inputs/outputs (24 V DC)	1 kV
Digital inputs/outputs (120 V AC...240 V AC)	2 kV
Analog inputs/outputs	1 kV
CS31 bus	1 kV
Serial RS-485 interfaces (COM)	1 kV
Serial RS-232 interfaces (COM, not for PM55x and PM56x)	1 kV
ARCNET	1 kV
FBP	1 kV
Ethernet	1 kV
I/O supply (DC-out)	1 kV

Table 6: Immunity against the influence of line-conducted interferences (CW conducted), according to IEC 61000-4-6, zone B, criterion A

Parameter	Value
Test voltage	3V zone B, 10 V is also met.
High energy surges	According to IEC 61000-4-5, zone B, criterion B
Power supply DC	1 kV CM / 0.5 kV DM ²⁾
DC I/O supply	0.5 kV CM / 0.5 kV DM ²⁾
Communication Lines, shielded	1 kV CM ²⁾
AC I/O unshielded ³⁾	2 kV CM / 1 kV DM ²⁾
I/O analog, I/O DC unshielded ³⁾	1 kV CM / 0.5 kV DM ²⁾
Radiation (radio disturbance)	According to IEC 55011, group 1, class A

²⁾ CM = Common Mode, DM = Differential Mode

³⁾ When DC I/O inputs are used with AC voltage, external filters limiting high energy surges to 1 kV CM / 0.5 DM are required to meet requirements according IEC 61131-2.

4.6 Mechanical data

Parameter	Value
Mounting	Horizontal
Degree of protection	IP 20
Housing	Classification V-2 according to UL 94
Vibration resistance acc. to EN 61131-2	all three axes 2 Hz...8.4 Hz, continuous 3.5 mm 8.4 Hz...150 Hz, continuous 1 g (higher values on request)

Parameter	Value
Shock test	All three axes 15 g, 11 ms, half-sinusoidal
Mounting of the modules:	
DIN rail according to DIN EN 50022	35 mm, depth 7.5 mm or 15 mm
Mounting with screws	Screws with a diameter of 4 mm
Fastening torque	1.2 Nm

4.7 Approvals and certifications

Information on approvals and certificates can be found in the corresponding chapter of the *Main catalog, PLC Automation*.

5 System data AC500-XC



Assembly, construction and connection of devices of the variant AC500-XC is identical to AC500 (standard). The following description provides information on general technical data of AC500-XC system.

5.1 Environmental conditions

Table 7: Process and supply voltages

Parameter	Value
24 V DC	
Voltage	24 V (-15 %, +20 %)
Protection against reverse polarity	Yes
120 V AC...240 V AC wide-range supply	
Voltage	120...240 V (-15 %, +10 %)
Frequency	50/60 Hz (-6 %, +4 %)
Allowed interruptions of power supply	
DC supply	Interruption < 10 ms, time between 2 interruptions > 1 s, PS2



NOTICE!

Exceeding the maximum power supply voltage for process or supply voltages could lead to unrecoverable damage of the system. The system might be destroyed.



NOTICE!

For the supply of the modules, power supply units according to PELV or SELV specifications must be used.



The creepage distances and clearances meet the requirements of the overvoltage category II, pollution degree 2.

Parameter	Value
Temperature	
Operating	<p>-40 °C...+70 °C</p> <p>-40 °C...-30 °C: Proper start-up of system; technical data not guaranteed</p> <p>-40 °C...0 °C: Due to the LCD technology, the display might respond very slowly.</p> <p>-40 °C...+40 °C: Vertical mounting of modules possible, output load limited to 50 % per group</p> <p>+60 °C...+70 °C with the following deratings:</p> <ul style="list-style-type: none"> • System is limited to max. 2 communication modules per terminal base • Applications certified for cULus up to +60 °C • Digital inputs: maximum number of simultaneously switched on input channels limited to 75 % per group (e.g. 8 channels => 6 channels) • Digital outputs: output current maximum value (all channels together) limited to 75 % per group (e.g. 8 A => 6 A) • Analog outputs only if configured as voltage output: maximum total output current per group is limited to 75 % (e.g. 40 mA => 30 mA) • Analog outputs only if configured as current output: maximum number of simultaneously used output channels limited to 75 % per group (e.g. 4 channels => 3 channels)
Storage / Transport	-40 °C...+85 °C
Humidity	Operating / Storage: 100 % r. H. with condensation
Air pressure	<p>Operating:</p> <p>-1000 m...4000 m (1080 hPa...620 hPa)</p> <p>> 2000 m (< 795 hPa):</p> <ul style="list-style-type: none"> • max. operating temperature must be reduced by 10 K (e.g. 70 °C to 60°C) • I/O module relay contacts must be operated with 24 V nominal only
Immunity to corrosive gases	<p>Operating: Yes, according to:</p> <p>ISA S71.04.1985 Harsh group A, G3/GX</p> <p>IEC 60721-3-3 3C2 / 3C3</p>
Immunity to salt mist	<p>Operating: Yes, horizontal mounting only, according to IEC 60068-2-52 severity level: 1</p>

! **NOTICE!**
Risk of corrosion!
 Unused connectors and slots may corrode if XC devices are used in salt-mist environments.
 Protect unused connectors and slots with TA535 protective caps for XC devices.

Table 8: Electromagnetic compatibility

Parameter	Value
Device suitable for:	
Industrial applications	Yes
Domestic applications	No
Radiated emission (radio disturbances)	Yes, according to: CISPR 16-2-3
Conducted emission (radio disturbances)	Yes, according to: CISPR 16-2-1, CISPR 16-1-2
Electrostatic discharge (ESD)	Yes, according to: IEC 61000-4-2, zone B, criterion B
Fast transient interference voltages (burst)	Yes, according to: IEC 61000-4-4, zone B, criterion B
High energy transient interference voltages (surge)	Yes, according to: IEC 61000-4-5, zone B, criterion B
Influence of radiated disturbances	Yes, according to: IEC 61000-4-3, zone B, criterion A
Influence of line-conducted interferences	Yes, according to: IEC 61000-4-6, zone B, criterion A
Influence of power frequency magnetic fields	Yes, according to: IEC 61000-4-8, zone B, criterion A

i *In order to prevent malfunctions, it is recommended, that the operating personnel discharge themselves prior to touching communication connectors or perform other suitable measures to reduce effects of electrostatic discharges.*

**NOTICE!****Risk of malfunctions!**

Unused slots for communication modules are not protected against accidental physical contact.

- Unused slots for communication modules must be covered with dummy communication modules to achieve IP20 rating.
- I/O bus connectors must not be touched during operation.

5.2 Mechanical data

Parameter	Value
Wiring method	Spring terminals
Degree of protection	IP 20
Vibration resistance	Yes, according to: IEC 61131-2 IEC 60068-2-6 IEC 60068-2-64
Shock resistance	Yes, according to: IEC 60068-2-27
Assembly position	Horizontal Vertical (no application in salt mist environment)
Assembly on DIN rail	
DIN rail type	According to IEC 60715 35 mm, depth 7.5 mm or 15 mm
Assembly with screws	
Screw diameter	4 mm
Fastening torque	1.2 Nm

5.3 Environmental tests

Parameter	Value
Storage	IEC 60068-2-1 Test Ab: cold withstand test -40 °C / 16 h IEC 60068-2-2 Test Bb: dry heat withstand test +85 °C / 16 h
Humidity	IEC 60068-2-30 Test Db: Cyclic (12 h / 12 h) damp-heat test 55 °C, 93 % r. H. / 25 °C, 95 % r. H., 6 cycles IEC 60068-2-78, stationary humidity test: 40 °C, 93 % r. H., 240 h
Insulation Test	IEC 61131-2
Vibration resistance	IEC 61131-2 / IEC 60068-26: 5 Hz...500 Hz, 2 g (with memory card inserted) IEC 60068-2-64: 5 Hz...500 Hz, 4 g rms
Shock resistance	IEC 60068-2-27: all 3 axes 15 g, 11 ms, half-sinusoidal

Table 9: EMC immunity

Parameter	Value
Electrostatic discharge (ESD)	Electrostatic voltage in case of air discharge: 8 kV Electrostatic voltage in case of contact discharge: 6 kV
Fast transient interference voltages (burst)	Supply voltage units (DC): 4 kV Digital inputs/outputs (24 V DC): 2 kV Analog inputs/outputs: 2 kV Communication lines shielded: 2 kV I/O supply (DC-out): 2 kV
High energy transient interference voltages (surge)	Supply voltage units (DC): 1 kV CM *) / 0.5 kV DM *) Digital inputs/outputs (24 V DC): 1 kV CM *) / 0.5 kV DM *) Digital inputs/outputs (AC): 4 kV Analog inputs/outputs: 1 kV CM *) / 0.5 kV DM *) Communication lines shielded: 1 kV CM *) I/O supply (DC-out): 0,5 kV CM *) / 0.5 kV DM *)
Influence of radiated disturbances	Test field strength: 10 V/m
Influence of line-conducted interferences	Test voltage: 10 V
Power frequency magnetic fields	30 A/m 50 Hz 30 A/m 60 Hz

*) CM = Common Mode, * DM = Differential Mode